

One touch does it!



**MONITECH**  
PRACTICAL SOLUTIONS FOR INDUSTRIAL DISPLAYS



# IMPORTANT

## WARRANTY

Before using any MONITECH product please carefully review this Manual as well as any additional documentation provided with your shipment.

### Attempting any of the following will void product warranty:

- unauthorized repairs or parts replacement
- inappropriate use or placement: exposing product to liquids, harmful gases, electrical shock, physical shock, temperatures beyond the range of -4°F to 140°F (-20°C to 60°C)
- use of electrical voltage other than 12V 4.16A (power supply and AC cable provided)
- removal or modification of serial, product, or warranty labels.

	<b>WARNING</b>	
	<b>ELECTRICAL HAZARD DO NOT OPEN</b>	
<p>TO AVOID ELECTRICAL SHOCK DO NOT OPEN PRODUCT CASING. UNAUTHORIZED REPAIRS OR PARTS REPLACEMENT ARE PROHIBITED AND WILL VOID PRODUCT WARRANTY. PLEASE RETURN TO MONITECH FOR REPAIRS.</p>		

# 1. Secure a video signal.

Once you have mounted your new Monitech LCD into your control panel with the video and power cables attached, the monitor will power up automatically. It should also start receiving the video signal from your machine. If you are getting no video signal, your screen will be blue. Make sure the video cable is secured. To be sure, unplug and reinsert.

# 2. Press AUTO.



Press **AUTO** on the 6-button menu found on the back of the LCD. After a few seconds, the screen will center the image and automatically adjust the image size, color, brightness and contrast.

That's all there is to it! Your LCD is ready to go.

### 3. Adjust brightness and contrast.

If you do need to adjust brightness or contrast, here's how. Press MENU and this image appears:



Use the up ▲ or down ▼ arrows to move between items vertically.

Use the right ► and left ◀ arrows to adjust values.

Press **MENU** to select an item. Select **AUTO** to exit or go back.

### 4. Adjust size and position.

Choose "Image alignment" to adjust size if necessary.

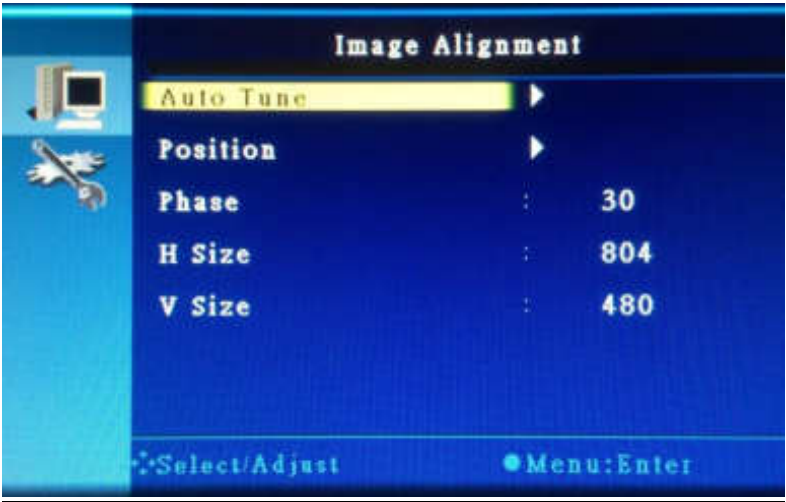

## 5. Adjust features.

If you need a language other than English, press MENU and then the ▼ arrow. This image appears:



## Video connector

This picture shows the value for six pins on the video connector at the back of the monitor. (The other pins are not used.)

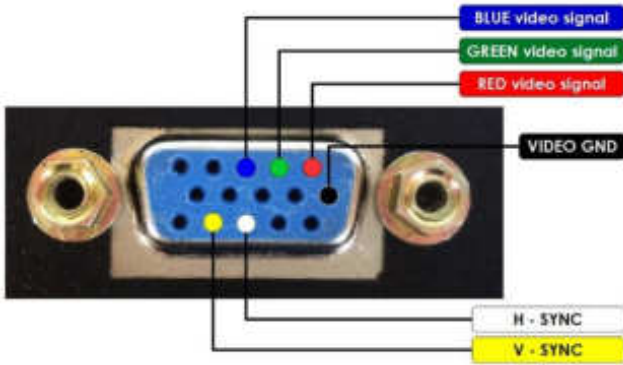

# Troubleshooting

**My screen is blue and says NO SYNC.**

**Or**

**The LED at the rear of the monitor is red.**

This means the LCD is getting no video signal from the machine. Reseat the video connector and secure it. Once the video signal is secured, the red light at the back will turn green.

**How do I deal with intermittent video issues?**

Ensure the video cable does not run close to high-power devices or cables. Ensure they are securely seated and free of damage.

**My video seems jittery.**

This is caused by a grounding issue. Check your grounds.

For Technical Support, Call  
**1-877-493-6105**  
Support@Monitech.com



20 Howard Place  
Kitchener, Ontario N2K 2Z4 Canada  
519-725-2222  
[www.monitech.com](http://www.monitech.com)  
[sales@monitech.com](mailto:sales@monitech.com)